

Zebra® 105SL™

Thermal, On-Demand, All-Metal Bar Code Printer



Serious about bar coding? Here's the choice of experience.

The 105SL combines enhanced memory, processing capacity, and features with rugged and reliable all-metal construction. Proven platform longevity plus fast processing and print speed make it the choice of experienced users who value reliability, productivity, consistent print quality, network compatibility, and superior service and support.

Cutting-Edge Network Connectivity

The 105SL offers flexible connectivity options including ZebraNet® Internal Wireless Plus print server to free you to move or reconfigure the printer without costly recabling, plus ZebraNet 10/100 Print Server, which offers a complete wired solution when using 10Base-T, 100Base-TX, and fast Ethernet 10/100 auto-switching networks. And with Zebra advanced printer management, gain the efficiency and the ease of centralized monitoring and control of your Zebra printers and ZebraNet print servers.

The 105SL is ideal for moderate- to high-volume printing applications (including distributed, batch, or single format) in:

- Manufacturing and compliance labeling
- Logistics and inventory control
- Product identification marking
- Work in process

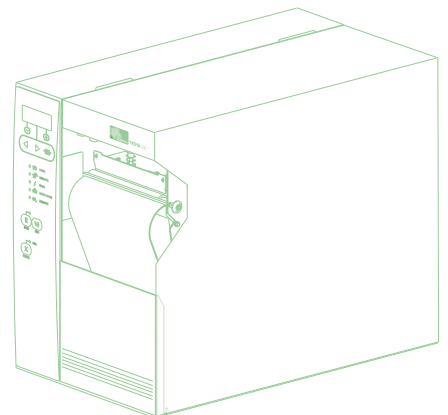



105SL

A tough steel housing, metal interior components, and an extruded metal printhead mechanism contribute to the 105SL's reliability in industrial environments.

Specifications at a Glance*

STANDARD FEATURES

Print methods: Thermal transfer or direct thermal
 Construction: Steel frame and cabinet with metal interior components
 Single-level Element Energy Equalizer™ (E³™) for superior print quality
 Fast 32-bit processing
 Selectable print speeds up to 8"/second
 Transmissive media sensor
 Standard 2-line, 16-character LCD control panel
 Internal real-time clock
 Unicode™ compliant
 XML-Enabled printing—direct-connect integration for bar code label printing; eliminates license fees and print server hardware and lowers customization and programming costs

PRINTER SPECIFICATIONS

Resolution

203 dpi/8 dots per mm;
 300 dpi/12 dots per mm (optional)

Memory

Standard: 6 MB SDRAM; 4 MB Flash
 Optional: Up to 256 MB—PCMCIA card or CompactFlash® (CompactFlash not supported with ZebraNet Wireless Plus)
 64 MB Flash memory (factory installed)

Print Width

Width: 4.09"/104 mm

Print Length with 203 dpi:

106"/2,692 mm (with standard memory)

Print Length with 300 dpi (optional):

65"/1,651 mm (with standard memory)

Print Speed

8"/203 mm per second (203/300 dpi)

Media Sensors

Transmissive (standard) and Reflective (optional)

MEDIA CHARACTERISTICS

Maximum label and liner length

39"/991 mm

Maximum label and liner width

.79"/20 mm to 4.52"/115 mm

Maximum roll outer diameter (O.D.)

8"/203 mm

Core inner diameter (I.D.)

3"/76 mm

Media thickness

.003"/.076 mm to .012"/.305 mm

Media types

Roll-feed, die-cut, continuous, fanfold, tags, tickets
 For optimum print quality and printer performance, use genuine Zebra™ supplies.

RIBBON CHARACTERISTICS

Outside diameter

3.2"/81.3 mm

Standard length

984'/300 m to 1,476'/450 m

Ratio

2:1 and 3:1 media roll to ribbon ratio

Width

.79"/20 mm to 4.5"/114 mm

Ribbon setup

Ribbon wound ink side out
 Ribbon is recommended to be at least as wide as media.

Core inner diameter (I.D.)

1"/25.4 mm

OPERATING CHARACTERISTICS

Environmental

Operating Temp. 32° F/0° C to 104° F/40° C
 Storage/Environ. -40° F/-40° C to 140° F/60° C
 Operating Humidity 20-85% non-condensing
 Storage Humidity 5-85% non-condensing

Electrical

Universal power supply with factor correction
 90-264 VAC; 48-63 Hz

Agency Approvals

UL 1950; CISPR 22 (Class B); CSA 950; IEC 950;
 801-2, -3 and -4 standards; Canadian Doc. (Class A); FCC (Class A); CE compliance

PHYSICAL CHARACTERISTICS

Width: 11.2"/283 mm
 Height: 15.5"/394 mm
 Depth: 19.5"/495 mm
 Weight: 55 lbs/25 kg
 Shipping weight: 63 lbs./29 kg

RELATED PRODUCTS

Options and Accessories

300 dpi printhead
 Full width cutter with orderable catch tray
 Internal rewind spindle
 Peel/liner rewind (for print-and-apply)
 Reflective media sensor
 Fanfold bin

ZEBRALINK™ SOLUTIONS

Software

ZebraDesigner™ Pro
 ZebraDesigner for XML
 ZebraDesigner
 ZebraNet™ Bridge Enterprise
 ZebraNet Utilities v 7.0
 Zebra Universal Driver
 European and Asian font sets
 ZBI-Developer™

Networking

ZebraNet® 10/100 Print Server (internal or external)
 ZebraNet Internal Wireless Plus
 ZebraNet Wireless Plus
 ZebraNet PrintServer II (external)
 Twinax and coax interfaces (internal)

Firmware

ZPL II®
 Global Printing
 APL™
 Web View
 Alert
 XML-Enabled printing
 ZBI 2.0™

COMMUNICATION AND INTERFACE CAPABILITIES

Centronics® RS-232 RS-422*, and RS-485* serial ports; IEEE 1284 bi-directional parallel

BAR CODE SYMBOLOGIES

Linear Bar Codes

Code 11, Code 39, Code 93, Code 128 with subsets A/B/C and UCC Case Codes, ISBT-128, UPC-A, UPC-E, EAN-8, EAN-13, UPC and EAN 2 or 5 digit extensions, Plessey, Postnet, Standard 2-of-5, Industrial 2-of-5, Interleaved 2-of-5, Logmars, MSI, Codabar, GS1 DataBar (RSS)

2-Dimensional

Codablock, PDF417, Code 49, Data Matrix, MaxiCode, QR Code, MicroPDF417, GS1 DataBar (RSS), Aztec

FONTS AND GRAPHICS

Fonts and Character Sets

Standard Fonts: 7 bitmapped, 1 smooth scalable (CG Triumvirate™ Bold Condensed)
 Sets: IBM® Code Page 850 International character set
 Contains UFST® from Monotype Imaging, Inc.

Graphic Features

Supports user-defined fonts and graphics—including custom logos
 ZPL II drawing commands—including boxes, circles and diagonal lines

*Specifications subject to change without notice.

©2008 ZIH Corp. ZebraDesigner, ZebraLink, ZebraNet, ZBI 2.0, ZBI-Developer, APL, Element Energy Equalizer, E³, and all product names and numbers are Zebra trademarks and Zebra, the Zebra head graphic, ZebraNet, and ZPL II are registered trademarks of ZIH Corp. All rights reserved. Centronics is a registered trademark of Centronics Data Computer Corporation. CG Triumvirate and UFST are trademarks of Monotype Imaging, Inc. and may be registered in certain jurisdictions. IBM is a trademark or registered trademark of International Business Machines Corporation in the United States, other countries, or both. CompactFlash is a registered trademark of SanDisk Corporation. Unicode is a trademark of Unicode, Inc. All other trademarks are the property of their respective owners.

For more information, call CDCE at 800-373-5353 or email sales@cdce.com